



Service Manual for DS-781/782(RS)

Edition	Month	Year
1st	Sep.	2008
2nd		
3rd		
4th		
5th		

SHANGHAI TERAOKA ELECTRONIC CO., LTD.

Ting Lin Industrial Development Zone, Jin Shan District, Shanghai P. R. China 201505

Tel: +86-21-5723-4888

Fax: +86-21-5723-4090

Web: www.digi-scale.com

Contents

1. General Layout	5
1.1. Bench Type	5
1.2. Pole Type	6
2. Purpose	7
3. Features	7
4. Operating Conditions.....	8
5. Analog Specification	8
6. Capacity/Minimum Graduation/Tare range	8
6.1. Single Interval	8
6.2. Multi-Interval	8
7. Display and Indicators	9
7.1. Display Specifications	9
7.2. Indicators	9
8. Dimensions	9
9. External Connectors	9
10. Main Components	9
11. Existing parts to be used.....	9
12. Keysheet Layout.....	9
13. Key Functions.....	10
13.1. Type A (11 Preset keys)	10
13.2. Type B (15 Preset keys)	10
14. Block Diagram of Electrical Connection	11
15. Physical layout of Electrical Connection	13
16. Hardware Description	14
16.1. Microcomputer	14
16.2. Pin Assignment	15
17. Maintenance Mode	16
17.1. SPAN Switch and Software Version Check	16
17.2. SPAN Adjustment	16
17.2.1. Full capacity weight for SPAN Adjustment	16
17.2.2. Proportion of capacity weight for SPAN Adjustment	17
17.3. Escape from Maintenance mode	17
17.4. Specification Setting	18
17.4.1. Specification Enter (141)	18
17.4.2. Specification Enter (142)	18
17.5. Internal Count & A/D Count Display	19
17.6. Tax Setting	19
17.7. Operational Specification List	19
18. Operations In Weighing Mode	25
18.1. ON/OFF	25
18.2. Tare Subtraction	25
18.2.1. One Touch Tare Subtraction	25
18.2.2. Digital Tare Subtraction	25
18.3. Plural Operation	26
18.3.1. Standard Version	26
18.3.2. Japan Type A Version	26

18.3.3. Japan Type B Version	26
18.4. Multiplication Operation	27
18.4.1. Standard Version	27
18.4.2. Japan Type A Version	27
18.4.3. Japan Type B Version	27
18.5. AMT/TEND Key Operation	28
18.5.1. Method A (Direct entry method: SPEC30.1 = 1)	28
18.5.2. Method B (Indirect entry method: SPEC30.1 = 0)	28
18.6. Correction Of Past Sales Data	28
18.7. Price Base Change By 100g/kg Key	29
18.8. Auto Zero Operation	29
18.9. kg and lb conversion by UNIT Key	29
18.10. kg, decimal lb and kati conversion by UNIT Key	30
18.11. Currency Conversion by EURO Key	30
18.11.1. Currency Conversion Operation Method 1 (SPEC4.32 = 01)	30
18.11.2. Currency Conversion Operation Method 2 (SPEC4.32 = 10)	30
19. Operations of Mode Set Key	31
19.1. Mode Change Using Mode Set Key	31
19.2. PLU Setting	31
19.3. Preset Key Setting	31
19.3.1. Preset Key Setting when PLU function is allowed.	31
19.3.2. Preset Key Setting when PLU function is inhibited.	32
19.4. Conversion Rate Setting	32
19.5. Invert Currency Conversion Function	32
19.6. Cancel Currency Conversion Function	33
20. RS-232C Interface	33
20.1. Specification	33
20.2. Pin Assignment	33
20.3. Control Code and Characters	33
20.4. Data Format	35
20.5. Communication Method	36
20.5.1. Type A (Standard Stream)	37
20.5.2. Type W (Standard Manual)	38
20.5.3. Type B (Standard Command)	39
21. Error Message List	39

Features of DS781/782:



Bottom



Front (Pole Type)



Side (Pole Type)

- ①: Power Interface
- ②: Backup battery
- ③: Operator displays
- ④: Keyboard
- ⑤: Platter
- ⑥: Nameplate
- ⑦: Customer displays (Pole Type)

1. General Layout

1.1. Bench Type

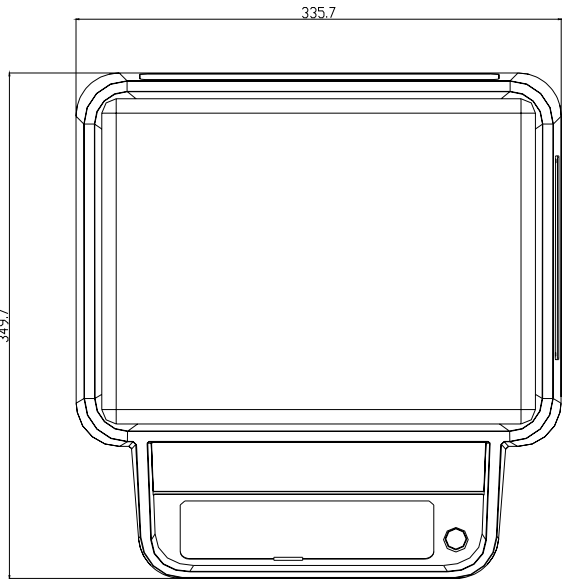
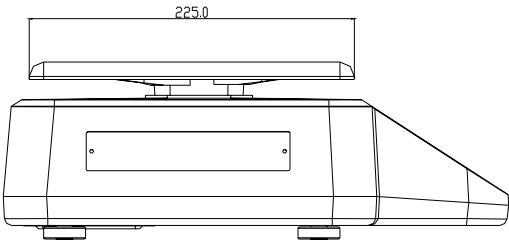
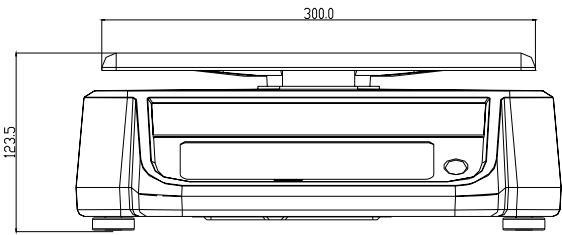

1.2. Pole Type

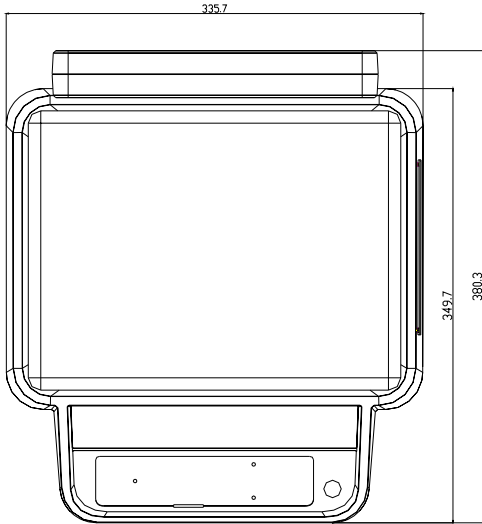
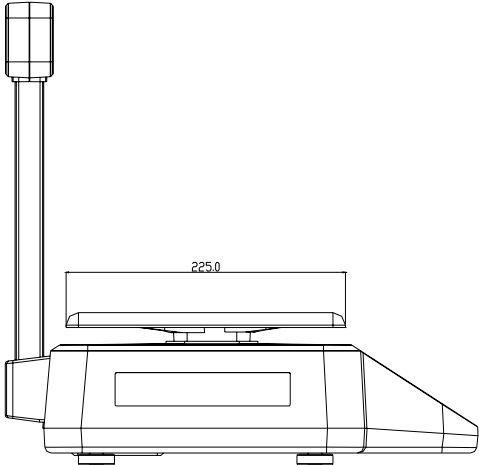
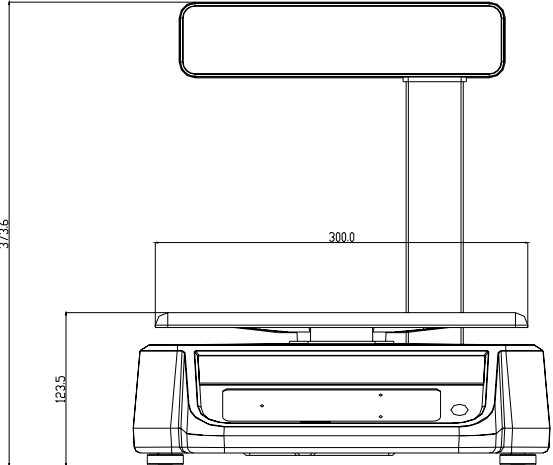

2. Purpose

To develop a low power consumption digital price computing scale which caters OIML Standard.

3. Features

* Low power consumption LCD digital price computing scale.(DS781)

Low power consumption LCD with back-light digital price computing scale.(DS782)

* Quick response to weight changes.

* Capacity : 3kg, 6kg, 15kg, 30kg, 6lb, 15lb, 30lb and 60lb.

* Resolution : Display Resolution 1/3000.

Internal Resolution 1/90000.

* Low power consumption :

- **DS781**: Battery(4 x C size dry battery) backup for more than 200 hours of continuous usage.

- **DS781RS**: Battery(4 x C size dry battery) backup for more than 120 hours of continuous usage.

- **DS782**: Rechargeable Battery backup for more than 600 hours of continuous usage. (Back-light function is off)

- **DS782RS**: Rechargeable Battery backup for more than 380 hours of continuous usage. (Back-light function is off).

* Two-Point battery low detect(DS781)

A. When battery is weak, the Battery indicator will light up.

B. When the power from battery becomes low such that the scale can not compute accurately, all displays will shut off except the Battery indicator. The power is then shut off completely after 1minute.

* Intelligent power control(DS782)

A. When AC power is available, scale will use AC power only whatever rechargeable battery is installed or not. When AC power is shut off, scale will use battery automatically.

B. When scale works on rechargeable battery, if the battery is weak, the battery indicator will light up.

When the power from battery becomes low such that the scale can not compute accurately, all Displays will shut off except the Battery indicator. The power is then shut off completely after 1 minute.

C. Scale detects rechargeable battery voltage and control battery charge process automatically.

The battery indicator blinks when rechargeable battery is being charged.

* Calibration by software.

* Water proof keyboard and splash proof housing.

* Customer and operator displays.

* 33 keys:

- ON/OFF key.

- 10 Numeric keys.

- 11/7 Operational keys.

- 11/15 Preset keys.

* High contrast LCD display.(DS781)

* High contrast LCD display with back-light function.(DS782)

* Flat platter.

* 99 codes(PLU) can be programmed with unit price and/or tare.

* RS-232C interface (**DS781RS ,DS782RS only**).

4. Operating Conditions

DS781:

- * Power Source : 4 x C size dry battery or AC/DC Adapter(DC 5V ~ 8V, 100mA).
- * Operating Temperature : -10°C ~ +40°C.
- * Operating Humidity : 15 ~ 85% RH.
- * Power Consumption : 0.24W when DC 6V..
: 0.12W when using dry battery.

DS782:

- * Power Source : AC 240/230/220V, 117/100V.
: DC 6V 5Ah rechargeable battery (optional).
- * Operating Temperature : -10°C ~ +40°C.
- * Operating Humidity : 15 ~ 85% RH.
- * Power Consumption : 18W when using AC power.
: 1.2W when using rechargeable battery.

5. Analog Specification

- * Input sensitivity : 1mV/V.
- * Zero adjust range : 0 ± 3.3mV.
- * Zero balance range : 0 ± 0.33mV.
- * L/C applied voltage : DC 3.3V.
- * Speed of A/D conversion : 10 times/sec.
- * Internal Resolution : 90000.

6. Capacity/Minimum Graduation/Tare range

6.1. Single Interval

Capacity	Minimum Graduation	Tare Rang
3kg	1g (1e = 30IR)	0 - 1.499kg
6kg	2g (1e = 30IR)	0 - 2.998kg
15kg	5g (1e = 30IR)	0 - 7.495kg
30kg	10g (1e = 30IR)	0 - 14.99kg
6lb	0.002lb (1e = 30IR)	0 - 2.998lb
15lb	0.005lb (1e = 30IR)	0 - 7.495lb
30lb	0.01lb (1e = 30IR)	0 - 14.99lb
60lb	0.02lb (1e = 30IR)	0 - 29.98lb

6.2. Multi-Interval

Capacity	Minimum Graduation	Tare Rang
3kg	1g (1e = 10IR)	0 - 1.499kg
6kg	(0-3kg)-1g (1e=15IR) (3-6kg)-2g (1e=30IR)	0 - 2.999kg
15kg	(0-6kg)-2g (1e=12IR) (6-15kg)-5g (1e=30IR)	0 - 5.998kg
30kg	(0-15kg)-5g (1e=15IR) (15-30kg)-10g (1e=30IR)	0 - 9.995kg
6lb	(0-3lb)-0.001lb (1e=15IR) (3-6lb)-0.002lb (1e=30IR)	0 - 2.999lb
15lb	(0-6lb)-0.002lb (1e=12IR) (6-15lb)-0.005lb (1e=30IR)	0 - 5.998lb
30lb	(0-15lb)-0.005lb (1e=15IR) (15-30lb)-0.01lb (1e=30IR)	0 - 9.995lb
60lb	(0-30lb)-0.01lb (1e=15IR) (15-30lb)-0.02lb (1e=30IR)	0 - 29.99lb

*NOTE : IR -> Internal Resolution, e -> Division(Minimum Increment).
Internal count(full capacity) = 90000IR.

7. Display and Indicators

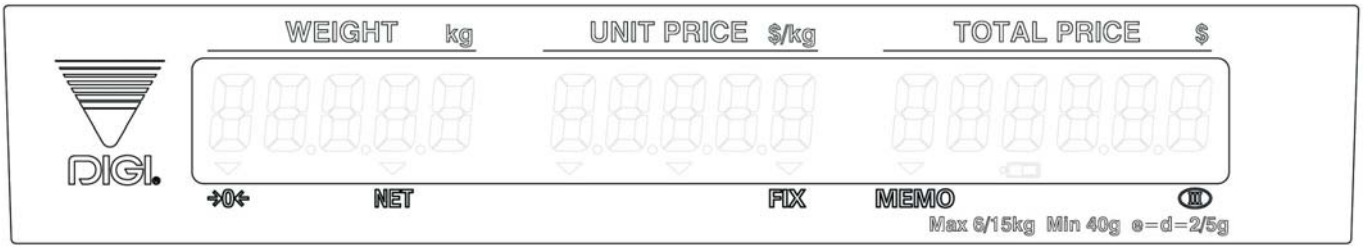

Standard

7.1. Display Specifications

- * Weight Display : 5 digits.
- * Unit Price Display : 5 digits.
- * Total Price Display : 6 digits.

7.2. Indicators

- * 0 : On when zero point is adjusted and weight is stable.
- * NET : On when tare subtraction is performed.
- * FIX : On when tare or PLU/unit price is fixed.
- * MEM : On when price is accumulating.
- *  : On when battery is weak and needs to change.

8. Dimensions

- * Platter size : 300 x 225 mm.
- * Overall size : 335.7(W) x 349.7(D) x 123.5(H) (Excluding Pole type customer side display).

9. External Connectors

- * DC receptacle.
- * RS-232C interface (DS781RS only).
- * RS-232C interface (DS782RS only).

10. Main Components

- * Microcomputer : R5F21255(16 bit, 24K ROM) / R5F21256(16 bit, 32K ROM) / R5F21257(16 bit, 48K ROM) / R5F21258(16 bit, 64K ROM).
- * Display device : LCD.
- * Loadcell : 1k resistance loadcell.

11. Existing parts to be used

- * Platter (DS-685).
- * J type Loadcell (DS-671).

12. Keysheet Layout

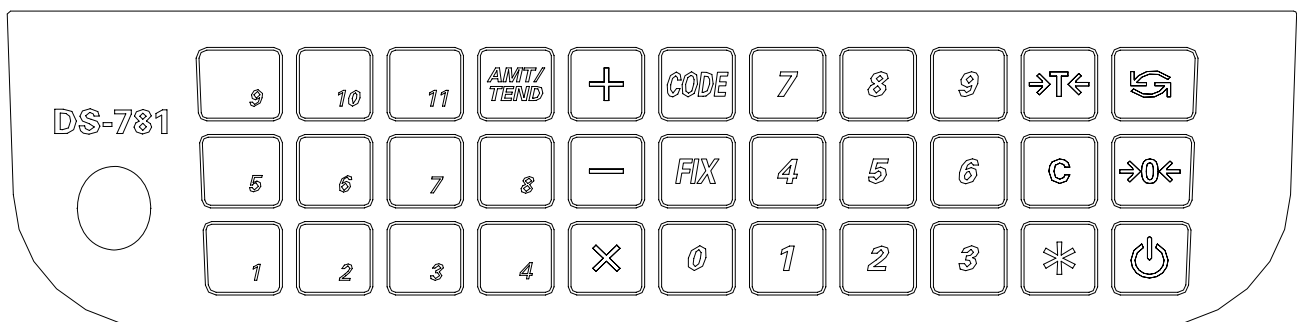

Type A

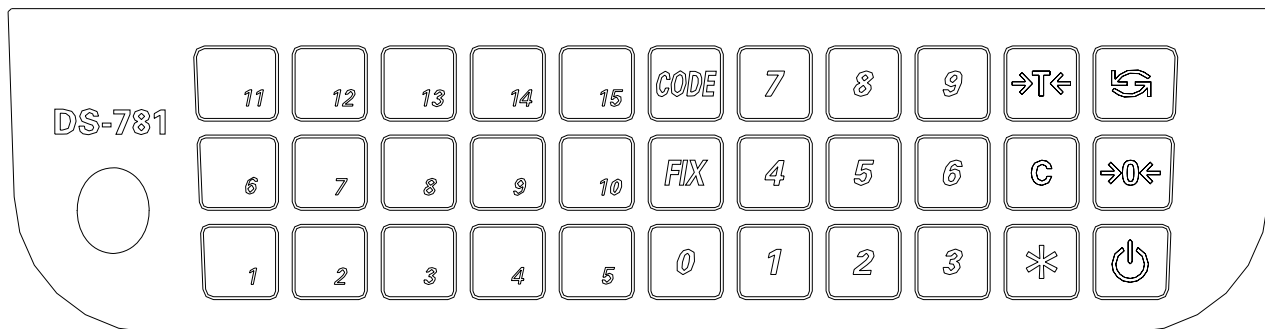



Type B



13. Key Functions

(The “mode”key is  and the “RE-ZERO”key is  in the keyboard)

13.1. Type A (11 Preset keys)

- ON/OFF : ON/OFF key. Turns the power ON or OFF.
- MODE : MODE SET key. Switch into following modes: Program Mode, Grand Total Check Mode.
- RE-ZERO : RE-ZERO key. Resets weight display to zero.
- T : TARE key. Set or clears tare value.
- C : CLEAR key. Clears numerical values.
- 0 to 9 : Numeric keys. Input numerical value.
- CODE : CODE key. Enter PLU code.
- FIX : FIX key. To fix tare weight or PLU/unit price.
- * : Data Setting key. Set up or clear mode.
Used as data send key for RS232C type.
- + : Accumulation key. Adds sum or accumulate sum.
- : Minus key. Correct operation on products.
- x : Multiply key. Register the same non-weighing product multiple times.
- AMT/TEND : Enters amount tendered. Two different types of AMT/TEND operation can be selected by SPEC.
-  to  : PRESET keys. Set up or call either unit price.

13.2. Type B (15 Preset keys)

- ON/OFF : ON/OFF key. Turns the power ON or OFF.
- MODE : MODE SET key. Switch into following modes: Program Mode, Grand Total Check Mode.
- RE-ZERO : RE-ZERO key. Resets weight display to zero.
- T : TARE key. Set or clears tare value.
- C : CLEAR key. Clears numerical values.
- 0 to 9 : Numeric keys. Input numerical value.
- CODE : CODE key. Enter PLU code.
- FIX : FIX key. To fix tare weight or PLU/unit price.
- * : Data Setting key. Set up or clear mode.
-  to  : PRESET keys. Set up or call either unit price.

14. Block Diagram of Electrical Connection

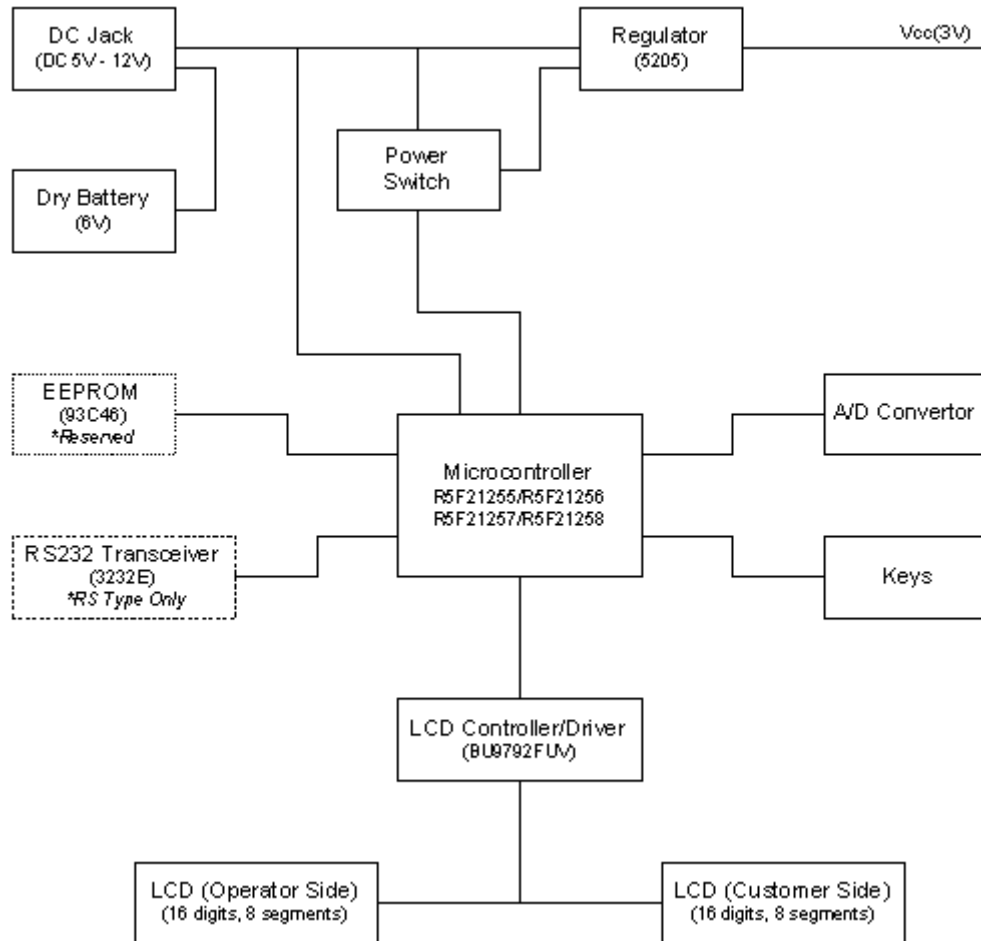

DS-781

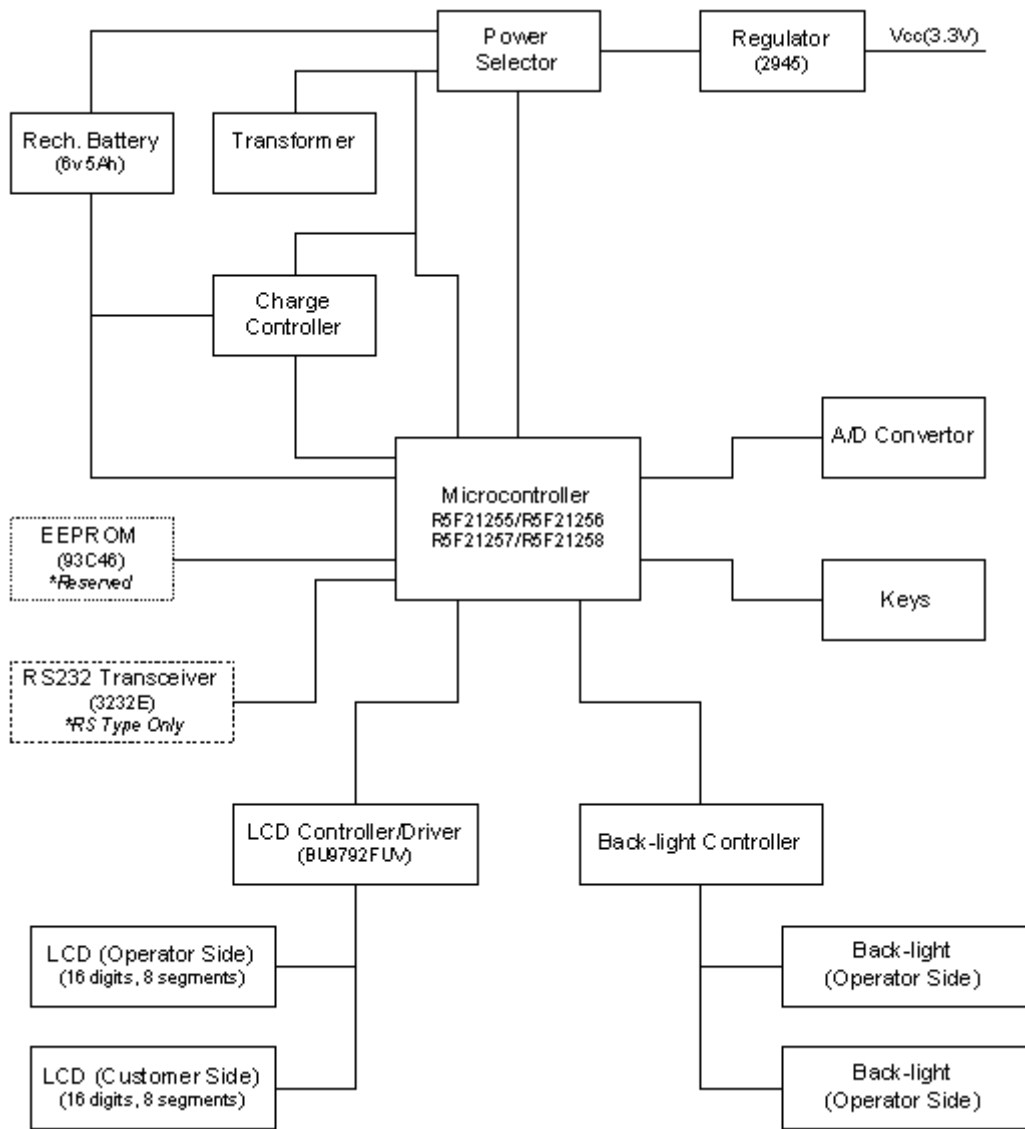

DS-782

15. Physical layout of Electrical Connection

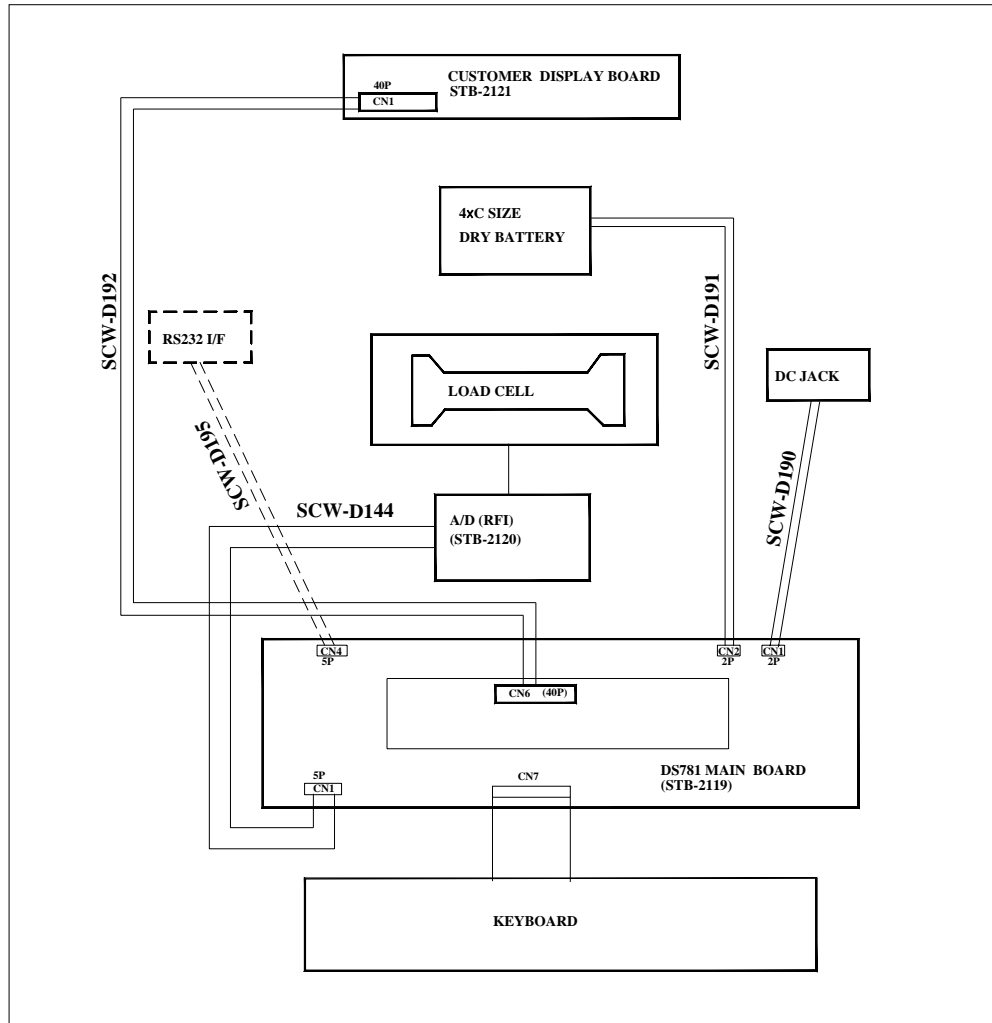

DS-781

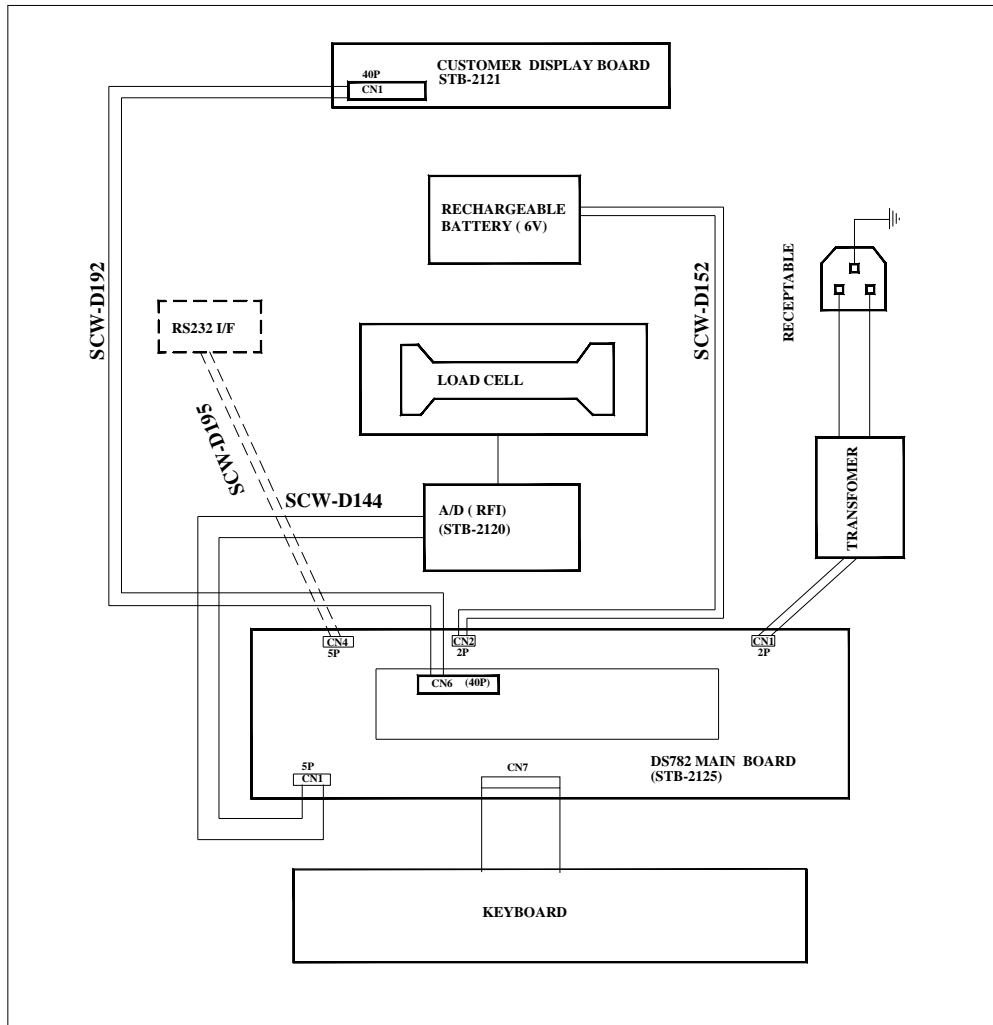

DS-782

16. Hardware Description

16.1. Microcomputer

The R5F21255 / R5F21256 / R5F21257 / R5F21258 Microcomputer was chosen for the following reasons:

- * Cheaper.
- * Low voltage low power consumption.
- * On-chip oscillator.
- * On-chip power-on reset circuit and voltage detection circuit.
- * Flash programming and erasure endurance: 1000 times for program ROM and 10000 times data flash.
- * 20 interrupt sources and efficient interrupt processing.
- * 4 versatile timers.
- * 12 channels 10-bit A/D converter.
- * Pin compatibility of similar package with difference ROM sizes.
- * Good support.

16.2. Pin Assignment

Pin	I/O	Assignment	Device	Remark
P00/AN7	I	DCVOLT(DS-781) ACVOLT(DS-782)	DC Power(DS-781) AC Power(DS-782)	Detects DC Power(DS-781) Detects AC Power(DS-782)
P01/AN6	O	BTVOLT *DS-782only	Battery *DS-782only	Detects Battery Voltage *DS-782only
P02/AN5	O	-	-	NC
P03/AN4	O	-	-	NC
P04/AN3	O	-	-	NC
P05/AN2	O	-	-	NC
P06/AN1	O	-	-	NC
P07/AN0	O	EEPCS	93C46	EEPROM CS (Reserved)
P10/K10/AN8	O	CBUZZ	Buzzer	Buzzer Sounder
P11/K11/AN9	O	EEPSK	93C46	EEPROM Serial Clock (Reserved)
P12/K12/AN10	O	EEPDO	93C46	EEPROM Serial Data Out (Reserved)
P13/K13/AN11	I	EEPDI	93C46	EEPROM Serial Data In (Reserved)
P14/TXD0	O	CTXD0	3232E	RS-232C TXD
P15/RXD0	I	CRXD0	3232E	RS-232C RXD
P16/CLK0	O	CRTS0	3232E	RS-232C RTS
P17/TRAI0/INT1	I	CCTS0	3232E	RS-232C CTS
P20/TRDIOA0	O	T1	Keyboard	Key Scanning Line
P21/TRDIOB0	O	T2	Keyboard	Key Scanning Line
P22/TRDIOC0	O	T3	Keyboard	Key Scanning Line
P23/TRDIOD0	O	T4	Keyboard	Key Scanning Line
P24/TRDIOA1	O	T5	Keyboard	Key Scanning Line
P25/TRDIOB1	O	T6	Keyboard	Key Scanning Line
P26/TRDIOC1	O	-	-	NC
P27/TRDIOD1	O	-	-	NC
P30/TRAO	O	BTPW	BATT-PW	Controls battery power
P31/TRBO	O	BTCHG *DS-782only	BATT-CHARGER *DS-782only	Controls battery charger *DS-782only
P33/SSI	O	CBKL *DS-782only	Back-light Controller *DS-782only	Controls Back-light *DS-782only
P34/SDA/SCS	O	SDA	BU9792FUV	LCD Controller/Driver Serial Clock
P35/SCL/SSCK	O	SCL	BU9792FUV	LCD Controller/Driver Serial Data
P37/SSO	O	-	-	NC
P42/VREF	I	-	-	A/D Reference Voltage
P43/XCIN	O	ADPOWN	TI1232	Power Down and Reset
P44/XCOUT	O	ADCLK	TI1232	Serial Clock
P45/INT0	I	ADDO	TI1232	Serial Data
P46/XIN	I	-	-	Connect to VCC via resistor
P47/XOUT	I	-	-	Connect to VCC via resistor
P60/TREO	I	K1	Keyboard	Key Return Line
P61	I	K2	Keyboard	Key Return Line
P62	I	K3	Keyboard	Key Return Line

Pin	I/O	Assignment	Device	Remark
P63	I	K4	Keyboard	Key Return Line
P64	I	K5	Keyboard	Key Return Line
P65/CLK1	I	K6	Keyboard	Key Return Line
P66/INT2/TXD1	O	-	-	NC
P67/INT3/RXD1	I	K_ON/OFF	Keyboard	Key Return Line
VCC/AVCC	I	-	-	Power Supply / Analog Power Supply
VSS/AVSS	I	-	-	Power Supply / Analog Power Supply
MODE	I	-	-	Mode Input
RESET	I	-	-	Reset Input

17. Maintenance Mode

17.1. SPAN Switch and Software Version Check

OPERATION	WEIGHT	U.PRICE	T.PRICE	1 - ZERO 2 - NET 3 - MEMORY 4 - BATTERY				REMARKS
				1	2	3	4	
[RE-ZERO]	0.000	0.00	0.00	▼				Weighing mode.
[RE-ZERO] + [2] [8] [4]	88888	88888	888888					Enter 2 8 4 while pressing [RE-ZERO].
	StE 28 (*DS-781)	V r x . x x	S - O N					
	StE 29 (*DS-782)							Display software ID code in weight column, version in unit price column. Display S-ON in total price column when SPAN switch is set to enable, Can access to 142 and calibration mode.
	StE 28 (*DS-781)	V r x . x x	S - O F F					Display S-OFF when SPAN switch is set to disable. Can not access to 142 and calibration mode.
	StE 29 (*DS-782)							
	0.000	0.00	0.00	▼				Goes back to Weighing mode after 3 seconds display.

17.2. SPAN Adjustment

NOTE: It can work only when SPAN SWITCH is on (Enable).

17.2.1. Full capacity weight for SPAN Adjustment

OPERATION	WEIGHT	U.PRICE	T.PRICE	1 - ZERO 2 - NET 3 - MEMORY 4 - BATTERY				REMARKS
				1	2	3	4	
[RE-ZERO]	0.000	0.00	0.00	▼				Weighing mode.
[RE-ZERO] + [8] [7] [1] [5]	88888	88888	888888					Enter 8 7 1 5 while pressing RE-ZERO.
Ensure no weight on platter, [*]	-----							Calibrating zero point.
Put full capacity weight on platter (e.g. 15kg), [*]	CAL00							Displays "CALSP" and full capacity(e.g. 15kg) alternately.
	15.000							Calibrating Span.
After calibration	-----							Goes back to Weighing mode.
	15.000	0.00	0.00					

17.2.2. Proportion of capacity weight for SPAN Adjustment

OPERATION	WEIGHT	U.PRICE	T.PRICE	1 - ZERO 2 - NET 3 - MEMORY 4 - BATTERY				REMARKS
				1	2	3	4	
[RE-ZERO]	0.000	0.00	0.00	▼				Weighing mode.
[RE-ZERO] + [8] [7] [1] [5]	88888	88888	888888					Enter 8 7 1 5 while pressing RE-ZERO.
Ensure no weight on platter, [*]	CAL00							Calibrating zero point.
Place weight to be calibrated on the Platter (e.g. 6kg)	-----							Calibrating zero point.
[C]	CALSP							Displays "CALSP" and full capacity(e.g. 15kg) alternately.
[C]	15.000							[C] key to set weight used for calibration.
[C]	13.500							Decreased at 10% of capacity rate.
[C]	12.000							Decreased at 10% of capacity rate.
:								
:								
[C]	6.000							Set to 6kg.
[*]	-----							Calibrating Span.
After calibration	6.000	0.00	0.00					Goes back to Weighing mode.
Put 15kg weight on platter	15.000	0.00	0.00					

17.3. Escape from Maintenance mode

OPERATION	WEIGHT	U.PRICE	T.PRICE	1 - ZERO 2 - NET 3 - MEMORY 4 - BATTERY				REMARKS
				1	2	3	4	
[RE-ZERO]	0.000	0.00	0.00	▼				Weighing mode.
[RE-ZERO] + [8] [7] [1] [5]	88888	88888	888888					Enter 8 7 1 5 while pressing RE-ZERO.
[T]	CAL00							RE-ZERO.
[T]	0.000	0.00	0.00	▼				Escape to Weighing mode.
[RE-ZERO]	88888	88888	888888					Enter 8 7 1 5 while pressing RE-ZERO.
[RE-ZERO] + [8] [7] [1] [5]	CAL00							RE-ZERO.
Ensure no weight on platter, [*]	-----							Calibrating zero point.
:								
:								
[T]	CALSP							
[T]	0.000	0.00	0.00	▼				Escape to Weighing mode.

17.4. Specification Setting

17.4.1. Specification Enter (141)

OPERATION	WEIGHT	U.PRICE	T.PRICE	1 - ZERO 2 - NET 3 - MEMORY 4 - BATTERY				REMARKS
				1	2	3	4	
[RE-ZERO]	8 8 8 8 8	8 8 8 8 8	8 8 8 8 8 8					Enter 1 4 1 while depressing
[RE-ZERO] + [1] [4] [1]	XXXX	XXXX	S P E C 0 0					RE-ZERO.
[+]	XXXX	XXXX	S P E C 0 1					+ key only increase Specification.
[-]	XXXX	XXXX	S P E C 0 0					- key only decrease Specification.
[8]	XXXX	0 0 0 8	S P E C 0 0					(00 ~ 19 is enabled)
[X]	XXXX	XXXX	S P E C 0 8					Goes to a designed Specification count.
[0] [1] [0] [1]	XXXX	0 1 0 1	S P E C 0 8					Only 1 & 0 are valid Specification data.
[*]	XXXX	XXXX	S P E C 0 9					* key to update Specification, increase
[1] [1] [0] [0]	XXXX	1 1 0 0	S P E C 0 9					Specification count.
[C]	XXXX	0 0 0 0	S P E C 0 9					Clears entered data.
[-]	0 1 0 1	0 1 0 1	S P E C 0 8					SPEC08 has been updated.
[T]	0.0 0 0	0.0 0	0.0 0	▼				Store SPECS to EEPROM & escape to Weighing mode.

17.4.2. Specification Enter (142)

NOTE: It can work only when SPAN SWITCH is on (Enable).

OPERATION	WEIGHT	U.PRICE	T.PRICE	1 - ZERO 2 - NET 3 - MEMORY 4 - BATTERY				REMARKS
				1	2	3	4	
	0.0 0 0	0.0 0	0.0 0	▼				Weighing mode.
[RE-ZERO]	8 8 8 8 8	8 8 8 8 8	8 8 8 8 8 8					Enter 1 4 2 while depressing
[RE-ZERO] + [1] [4] [2]	XXXX	XXXX	S P E C 2 0					RE-ZERO.
[+]	XXXX	XXXX	S P E C 2 1					+ key only increase Specification.
[-]	XXXX	XXXX	S P E C 2 0					- key only decrease Specification.
[2] [9]	XXXX	0 0 2 9	S P E C 2 0					(20 ~ 47 is enabled)
[X]	XXXX	XXXX	S P E C 2 9					Goes to a designed Specification count.
[0] [1] [0] [1]	XXXX	0 1 0 1	S P E C 2 9					Only 1 & 0 are valid Specification data.
[*]	XXXX	XXXX	S P E C 3 0					* key to update Specification, increase
[1] [1] [0] [0]	XXXX	1 1 0 0	S P E C 3 0					Specification count.
[C]	XXXX	0 0 0 0	S P E C 3 0					Clears entered data.
[-]	0 1 0 1	0 1 0 1	S P E C 2 9					SPEC29 has been updated.
[T]	0.0 0 0	0.0 0	0.0 0	▼				Store SPECS to EEPROM & escape to Weighing mode.

17.5. Internal Count & A/D Count Display

				1 - ZERO		2 - NET		3 - MEMORY		4 - BATTERY	
OPERATION	WEIGHT	U.PRICE	T.PRICE	1	2	3	4	REMARKS			
[RE-ZERO]	8 8 8 8 8	8 8 8 8 8	8 8 8 8 8 8					Enter 0 0 9 while depressing RE-ZERO. Weight and Unit Price column display A/D Count, Total Price column Display Internal Count. T key to go back Weighing mode.			
[RE-ZERO] + [0] [0] [9]	5	1 8 9 9 2	0								
[T]	0.0 0 0	0.0 0	0.0 0	▼							

17.6. Tax Setting

(Available when SPEC21.BIT2 = 0)

				1 - ZERO		2 - NET		3 - MEMORY		4 - BATTERY	
OPERATION	WEIGHT	U.PRICE	T.PRICE	1	2	3	4	REMARKS			
	0.0 0 0	0.0 0	0.0 0	▼				Weighing mode.			
[RE-ZERO]	8 8 8 8 8	8 8 8 8 8	8 8 8 8 8 8					Enter 9 9 9 while pressing RE-ZERO.			
[RE-ZERO] + [9] [9] [9]	t A	0.0 0	0.0 0					Enter Tax Rate, e.g. 3.00%.			
[3] [0] [0]	t A	0.0 0	3.0 0					RE-ZERO to store specification.			
[RE-ZERO]	r d 4 5	3.0 0	0.0 0					Depress 'C' to select Cut Off Or Rounding.			
[C]	C U t O F	3.0 0	0.0 0					Store Tax Rate to EEPROM & return to Weighing mode.			
[C]	r d 4 5	3.0 0	0.0 0								
[T]	0.0 0 0	0.0 0	0.0 0	▼							

17.7. Operational Specification List

For The Customer - (1 4 1)

SPEC NO.	BIT 3	BIT 2	BIT 1	BIT 0
0	Auto Power-off function			
	0000 - Disable		0100 - 1 hour	
	0001 - 3 minute		0101 - 3 hours	
	0010 - 10 minutes		0110 ~ 1111 - Not used	
	0011 - 30 minutes			
1	Buzzer	Error alarm	Weight sensitivity	
	0 - On	0 - On	00 - Low	10 - High Middle
	1 - Off	1 - Off	01 - Middle	11 - High
2	Tare override	Unit price override	Zero unit price override	
	0 - Allow	0 - Allow	0 - Allow	
	1 - Inhibit	1 - Inhibit	1 - Inhibit	
3	Back-light function	*DS-782 only	Auto back-light interval	*DS-782 only
			<i>(Effective only if SPEC01.32 set to 00)</i>	
	00 - Auto	10 - Always off	00 - 6s	10 - Not used
	01 - Always on	11 - Not used	01 - 15s	11 - Not used

4	Currency conversion operation method			
	00 - Inhibit currency conversion operation 01 - Method 1 10 - Method 2 11 - Not used			
5	Decimal point position on currency conversion rate			
	000 - 7th digit (0.XXXXXXX) 100 - 3rd digit (XXXX.XX) 001 - 6th digit (X.XXXXXX) 101 - 2nd digit (XXXXX.X) 010 - 5th digit (XX.XXXXX) 110 - No decimal point (XXXXXX) 011 - 4th digit (XXX.XXX) 111 - Not used			
6	RTS/CTS handshaking of RS-232C *RS type only	Baud rate of RS-232C *RS type only		
	0 - On 1 - Off	000 - 1200 bps 001 - 2400 bps 010 - 4800 bps 011 - 9600 bps	100 - 19200 bps 101 - 38400 bps 110 - Not used 111 - Not used	
7	Stop bit of RS-232C *RS type only	Data length of RS-232C *RS type only	Parity of RS-232C *RS type only	
	0 - 1 bit 1 - 2 bit	only 0 - 7 bit 1 - 8 bit	00 - None 01 - Odd	10 - Even 11 - Not used
8	Interval of time out error of RS-232C *RS type only		Transmission condition of RS-232C *RS type only	Additional parity code in text of RS-232C *RS type only
	00 - 1 second 01 - 3 second	10 - 5 second 11 - 10 second	0 - Weight stable 1 - Unconditional	0 - No 1 - Yes
9	Tare Weight in text of RS-232C *RS type only	Unit Price in text of RS-232C *RS type only	Total Price Weight in text of RS-232C *RS type only	
	0 - No 1 - Yes	0 - No 1 - Yes	0 - No 1 - Yes	

SPEC NO.	BIT 3	BIT 2	BIT 1	BIT 0
10	Data transfer protocol of RS-232C *RS type only 00000 - Inhibit data transfer 00001 - Type A (Standard stream) 00010 - Type W (Standard manual) 00011 - Type B (Standard command) 00100 - Type C (QUQA TRADING) 00101 - Type D (IBM, HUGIN) 00110 - Type E (ICL OLD) 00111 - Type F (ICL PORTUAGAL) 01000 - Type G (ICL ACTUAL) 01001 - Type H (CAS) 01010 - Type I (CAS PORTUAGAL) 01011 - Type J (NIXDORF) 01100 - Type K (NCR) 01101 - Type L (MONS) 01110 - Type M (Checkout-Dialog 02/04) 01111 - Type N (DATECS MP50/500) 10000 - Type O (NCI4000) 10001 - Type P (Checkout-Dialog 06) 10010 - Type Q (UNIWELL, ICL OLD OMRON) 10011 - Type R (ICL ACTUAL OMRON) 10100 - Type S (ICL CS500) 10101 - Type T (DTS) 10110 - Type U (SHARP UP-600/700, American Version) 10111 - Type V (NCI-ECR, Metrologic) 11000 - Type X (WTN) (sending key) 10111 ~ 11111 - Not used			
11				Data transfer protocol of RS-232C BIT4 of Data transfer protocol of RS-232C
12	Calculate and check validity of CS, KW (for Checkout-Dialog 06 only)	Key operation for tare in Pos-Weigh-Mode (for Checkout-Dialog 02/04 and 06 only)	Number of status bytes (for NCI-ECR only)	
	0 - No 1 - Yes	0 - Allow 1 - Inhibit	0 - 2 bytes 1 - 4 bytes	
13 - 19				

For Weight & Measure - (1 4 2)

NOTE: It can work only when the SPAN Switch is on (Enable)

SPEC NO.	BIT 3	BIT 2	BIT 1	BIT 0
20	Version display when power on 0 - Allow 1 - Inhibit	Selection of segment-check style 0 - Fast 1 - Standard	Start range 00 - $\pm 10\%$ F.S. 01 - $\pm 5\%$ F.S.	Start range 10 - $\pm 3\%$ F.S. 11 - $\pm 2\%$ F.S.
21	Price Base 00 - \$ / kg 01 - \$ / 100g		Re-zero range 00 - $\pm 2\%$ F.S. 01 - $\pm 3\%$ F.S.	Re-zero range 10 - Not used 11 - Not used
22	Decimal point position on weight display 00 - No decimal point 01 - 2nd digit (0000.0) 10 - 3rd digit (000.00) 11 - 4th digit (00.000)		Decimal point position on unit and total price display 00 - No decimal point for Unit & Total Price 01 - 2nd digit (0000.0) for Unit, 2nd digit (00000.0) for Total Price 10 - 3rd digit (000.00) for Unit, 3rd digit (0000.00) for Total Price 11 - Not used	
23	Minimum display 00 - 1 01 - 2		Selection of resolution 00 - 1/3000 01 - 1/6000	
24	Weight single interval or multi-interval 0 - Single interval 1 - Multi-interval	Net / Gross Multi-interval 0 - Gross 1 - Net	Negative weight display mask 00 - Minus gross $> 9e$ 01 - Minus gross weight 10 ~ 11 - Not used	
25	Rounding for total price 00 - Rounding 01 - Truncation		Re-zero function 0 - Allow 1 - Inhibit	Fix function 0 - Allow 1 - Inhibit
26	Additional rounding for total price 000 - No additional rounding 001 - 1/4 rounding (25 step) 010 - Special rounding (5 step) 011 - 5 floor rounding (0-4 \rightarrow 0, 5-9 \rightarrow 5) 100 - Rounding for 1 st digit 101 - Truncate 1 st digit 110 - Cut up 1 st digit 111 - Not used			Additional rounding for kati display 0 - Allow 1 - Inhibit

SPEC NO.	BIT 3	BIT 2	BIT 1	BIT 0
27	Manual tare cancellation 0 - Allow 1 - Inhibit	Tare subtraction 0 - Allow 1 - Inhibit	Tare accumulation 0 - Allow 1 - Inhibit	Auto tare clear when rezero 0 - Allow 1 - Inhibit
28	Digital tare 0 - Allow 1 - Inhibit	PLU tare / Preset tare 0 - Allow 1 - Inhibit	Accumulation when tare 0 - Allow 1 - Inhibit	Zero tracking when tare 0 - Allow 1 - Inhibit
29	Weight reset when tare 0 - Allow 1 - Inhibit	Tare auto clear 0 - Allow 1 - Inhibit	Unit price auto clear 0 - Allow 1 - Inhibit	Price Base auto clear 0 - Allow (For UK) 1 - Inhibit
30	Auto clear condition 0 - \geq Gross 21e & \geq Net 5e 1 - \geq Net 1e & price not 0	Tax 0 - Allow 1 - Inhibit	Change operation Method 0 - Indirect (method B) 1 - Direct (method A)	WT data synchronization (+ key only) 0 - Allow 1 - Inhibit
31	Accumulation number display 0 - Allow 1 - Inhibit	Accumulation display style 0 - Standard ("total") 1 - Japan ("Add")	Price accumulation without removing weight 0 - Allow 1 - Inhibit	Price accumulation without change weight (for $\geq \pm 10e$) 0 - Allow 1 - Inhibit
32	Exit from accumulation mode after 15 sec time out 0 - Allow 1 - Inhibit	Exit from accumulation mode when weight change 0 - Allow 1 - Inhibit	IR mode protected by SPAN SW 0 - No 1 - Yes	Password setting 0 - Allow 1 - Inhibit
33	Non-weigh item accumulation 0 - Allow 1 - Inhibit	Weight range of Non-weigh item 0 - Always 1 - Net 0d	Weight stability condition 00 - Loose 10 - Tight 01 - Normal 11 - Stringent	

34	Decimal point position on price display in secondary currency		Rounding for currency conversion	
	00 - No decimal point for Unit & Total Price 01 - 2nd digit (0000.0) for Unit, 2nd digit (00000.0) for Total Price 10 - 3rd digit (000.00) for Unit, 3rd digit (0000.00) for Total Price 11 - Not used		00 - Rounding 01 - Truncation 10 - Cut up 11 - Not used	
35	Exit from secondary currency mode when weight change (for > ±2e)	Currency symbol for secondary currency	Indicator for secondary currency	Inverse currency conversion function
	0 - Allow 1 - Inhibit	0 - No symbol 1 - 'EURO'	0 - Allow 1 - Inhibit	0 - Allow 1 - Inhibit
36	Accumulation	Subtraction	Multiplication	PLU function
	0 - Allow 1 - Inhibit	0 - Allow 1 - Inhibit	0 - Allow 1 - Inhibit	0 - Allow 1 - Inhibit
37	Price Base change key(100g/kg, 1/4lb/lb)	Currency conversion function	UNIT function	
	0 - Allow (For UK) 1 - Inhibit	0 - Allow 1 - Inhibit	00 - Inhibit 01 - kg and lb conversion 10 - kg, decimal lb and kati conversion (for HK) 11 - Not used	
38	Change function	Display hold	Auto Zero function	
	0 - Allow 1 - Inhibit	0 - Allow 1 - Inhibit	0 - Allow (for Japan) 1 - Inhibit	
39	Weight range of data output *RS type only	Permission of Weight change or remove check for data output (for NCI-ECR only)	Weight change or remove check of data output *RS type only	
	0 - Always 1 - Over 20e	0 - Allow 1 - Inhibit	0 - Change 1 - Remove	
40	Division for weight change check		*RS type only	
	0000 - 1e 0001 - 2e 0010 - 3e 0011 - 4e 0100 - 5e 0101 - 6e 0110 - 7e 0111 - 8e		1000 - 9e 1001 - 10e 1010 - 20e 1011 - 30e 1100 - 40e 1101 - 50e 1110 - 60e 1111 - 70e	

SPEC NO.	BIT 3	BIT 2	BIT 1	BIT 0
41 - 47				

18. Operations In Weighing Mode

18.1. ON/OFF

OPERATION	WEIGHT	U.PRICE	T.PRICE	1 - ZERO 2 - NET 3 - MEMORY 4 - BATTERY				REMARKS
				1	2	3	4	
[ON/OFF]	8.8.8.8.8.	8.8.8.8.8.	8.8.8.8.8.8.					Display for 1 seconds. *Note1 Blank for 1 seconds.
	8.8.8.8.8.	8.8.8.8.8.	8.8.8.8.8.8.					Display for 1 seconds. Blank for 1 seconds.
	8 8 8 8 8	8 8 8 8 8	8 8 8 8 8 8					
Ready to operate	0.0 0 0	0.0 0	0.0 0	▼				Weighing mode.
[ON/OFF]								OFF.

* Note1: Power On Segment Check Style can be selected by setting SPEC20.2. In this example assume SPEC20.2 = 0.

18.2. Tare Subtraction

18.2.1. One Touch Tare Subtraction

OPERATION	WEIGHT	U.PRICE	T.PRICE	1 - ZERO 2 - NET 3 - MEMORY 4 - BATTERY				REMARKS
				1	2	3	4	
	0.0 3 0	0.0 0	0.0 0					Put tare (e.g 30 g) on platter.
[T]	0.0 0 0	0.0 0	0.0 0		▼			Subtract the tare weight.
Remove the tare weight	- 0.0 3 0	0.0 0	0.0 0	▼	▼			
[T]	0.0 0 0	0.0 0	0.0 0	▼				Clear the tare weight.

18.2.2. Digital Tare Subtraction

OPERATION	WEIGHT	U.PRICE	T.PRICE	1 - ZERO 2 - NET 3 - MEMORY 4 - BATTERY				REMARKS
				1	2	3	4	
[5]	0.0 0 0	0.0 5	0.0 0	▼				Key in the tare weight (e.g 5g).
[T]	- 0.0 0 5	0.0 0	0.0 0	▼	▼			Subtract the tare weight (Assume 15kg).
[T]	0.0 0 0	0.0 0	0.0 0	▼				Clear the tare weight.

18.3. Plural Operation

18.3.1. Standard Version

OPERATION	WEIGHT	U.PRICE	T.PRICE	1 - ZERO 2 - NET 3 - MEMORY 4 - BATTERY				REMARKS
				1	2	3	4	
[1] [0] [0] [0]	0.0 0 0	1 0.0 0	0.0 0	▼				Enter unit price.
Put product on platter.	0.5 0 0	1 0.0 0	5.0 0					
[+]	t O t A L	1	5.0 0			▼		Accumulation the data.
Remove product from platter.	t O t A L	1	5.0 0			▼		
[1] [5] [0] [0]	0.0 0 0	1 5.0 0	0.0 0	▼		▼		Enter unit price.
[+]	t O t A L	2	2 0.0 0			▼		Fixed price accumulation.
[C]	0.0 0 0	0.0 0	0.0 0	▼		▼		Return to Weighing mode.
[+]	t O t A L	2	2 0.0 0			▼		Enter accumulation mode.
[+]	t O t A L	2	2 0.0 0			▼		Nothing happen.
[*]	0.0 0 0	0.0 0	0.0 0	▼				Clear current total & return to weighing mode.

18.3.2. Japan Type A Version

(When SPEC31.2 = 1 and SPEC31.3 = 0)

OPERATION	WEIGHT	U.PRICE	T.PRICE	1 - ZERO 2 - NET 3 - MEMORY 4 - BATTERY				REMARKS
				1	2	3	4	
[1] [0] [0] [0]	0.0 0 0	1 0.0 0	0.0 0	▼				Enter unit price.
Put product on platter.	0.5 0 0	1 0.0 0	5.0 0					
[+]	A d d	1]	5.1 5			▼		Accumulation the data(assume tax rate = 3%).
Remove product from platter.	A d d	1]	5.1 5			▼		
[1] [5] [0] [0]	0.0 0 0	1 5.0 0	0.0 0	▼		▼		Enter unit price.
[+]	A d d	2]	2 0.6 0			▼		Fixed price accumulation.
[*]	0.0 0 0	0.0 0	0.0 0	▼				Clear current total & return to weighing mode.

18.3.3. Japan Type B Version

(When SPEC31.2 = 1 and SPEC31.3 = 1)

OPERATION	WEIGHT	U.PRICE	T.PRICE	1 - ZERO 2 - NET 3 - MEMORY 4 - BATTERY				REMARKS
				1	2	3	4	
[1] [0] [0] [0]	0.0 0 0	1 0.0 0	0.0 0	▼				Enter unit price.
Put product on platter.	0.5 0 0	1 0.0 0	5.0 0					
[+]	A d d	5.0 0	5.1 5			▼		Accumulation the data (tax rate = 3%).
Remove product from platter.	A d d	5.0 0	5.1 5			▼		
[1] [5] [0] [0]	0.0 0 0	1 5.0 0	0.0 0	▼		▼		Enter unit price.
[+]	A d d	2 0.0 0	2 0.6 0			▼		Fixed price accumulation.
[*]	0.0 0 0	0.0 0	0.0 0	▼				Clear current total & return to weighing mode.

18.4. Multiplication Operation

18.4.1. Standard Version

OPERATION	WEIGHT	U.PRICE	T.PRICE	1 - ZERO 2 - NET 3 - MEMORY 4 - BATTERY				REMARKS
				1	2	3	4	
[1] [2] [3] [4]	0.0 0 0	1 2.3 4	0.0 0	▼				Enter unit price.
	0.4 1 2	1 2.3 4	5.0 8					Put product on platter.
[+]	t O t A L	1	5.0 8			▼		Accumulation the data.
[5] [0] [0]	0.0 0 0	5.0 0	0.0 0	▼		▼		Enter unit price.
[x]	P C S 0	5.0 0	0.0 0			▼		Depress multiply key.
[2] [0]	P C S 2 0	5.0 0	1 0 0.0 0			▼		multiply the data by 20.
[+]	t O t A L	2 1	1 0 5.0 8			▼		Accumulation the data.
[*]	0.0 0 0	0.0 0	0.0 0	▼				Clear current total & return to weighing mode.

18.4.2. Japan Type A Version

(When SPEC31.2 = 1 and SPEC31.3 = 0)

OPERATION	WEIGHT	U.PRICE	T.PRICE	1 - ZERO 2 - NET 3 - MEMORY 4 - BATTERY				REMARKS
				1	2	3	4	
[1] [2] [3] [4]	0.0 0 0	1 2.3 4	0.0 0	▼				Enter unit price.
	0.4 1 2	1 2.3 4	5.0 8					Put product on platter.
[+]	A d d	1]	5.2 3			▼		Accumulation the data (assume tax rate = 3%)
[5] [0] [0]	0.0 0 0	5.0 0	0.0 0	▼		▼		Enter unit price.
[x]	0]	5.0 0	0.0 0			▼		Depress multiply key.
[2] [0]	2 0]	5.0 0	1 0 0.0 0			▼		multiply the data by 20.
[+]	A d d	2 1]	1 0 8.2 3			▼		Accumulation the data.
[*]	0.0 0 0	0.0 0	0.0 0	▼				Clear current total & return to weighing mode.

18.4.3. Japan Type B Version

(When SPEC31.2 = 1 and SPEC31.3 = 1)

OPERATION	WEIGHT	U.PRICE	T.PRICE	1 - ZERO 2 - NET 3 - MEMORY 4 - BATTERY				REMARKS
				1	2	3	4	
[1] [2] [3] [4]	0.0 0 0	1 2.3 4	0.0 0	▼				Enter unit price.
	0.4 1 2	1 2.3 4	5.0 8					Put product on platter
[+]	A d d	5.0 8	5.2 3			▼		Accumulation the data (assume tax rate = 3%)
[5] [0] [0]	0.0 0 0	5.0 0	0.0 0	▼		▼		Enter unit price.
[x]	0]	5.0 0	0.0 0			▼		Depress multiply key
[2] [0]	2 0]	5.0 0	1 0 0.0 0			▼		multiply the data by 20
[+]	A d d	1 0 5.0 8	1 0 8.2 3			▼		Accumulation the data
[*]	0.0 0 0	0.0 0	0.0 0	▼				Clear current total & return to weighing mode.

18.5. AMT/TEND Key Operation

18.5.1. Method A (Direct entry method: SPEC30.1 = 1)

OPERATION	WEIGHT	U.PRICE	T.PRICE	1 - ZERO 2 - NET 3 - MEMORY 4 - BATTERY				REMARKS
				1	2	3	4	
[1] [2] [5] [0]	0.0 0 0	1 2.5 0	0.0 0	▼				Enter unit price.
Put product on platter.	0.4 2 0	1 2.5 0	5.2 5					
[+]	t O t A L	1	5.2 5			▼		Accumulation the data.
Remove product from platter.	t O t A L	1	5.2 5			▼		
[6] [0] [0]	0.0 0 0	6.0 0	0.0 0	▼		▼		Enter the amount tendered.
[AMT/TEND]	C H G		0.7 5					Compute change & clear current total.
[C]	0.0 0 0	0.0 0	0.0 0	▼				Return to Weighing mode.
[+]	t O t A L	0	0.0 0					Check total data.
[C]	0.0 0 0	0.0 0	0.0 0	▼				Return to Weighing mode.

18.5.2. Method B (Indirect entry method: SPEC30.1 = 0)

OPERATION	WEIGHT	U.PRICE	T.PRICE	1 - ZERO 2 - NET 3 - MEMORY 4 - BATTERY				REMARKS
				1	2	3	4	
[1] [2] [5] [0]	0.0 0 0	1 2.5 0	0.0 0	▼				Enter unit price.
Put product on platter.	0.4 2 0	1 2.5 0	5.2 5					
[+]	t O t A L	1	5.2 5			▼		Accumulation the data.
Remove product from platter.	t O t A L	1	5.2 5			▼		
[AMT/TEND]	t n d		5.2 5			▼		Prepare to compute change.
[6] [0] [0]	t n d		6.0 0			▼		Enter the amount tendered.
[*]	C H G		0.7 5					Compute change & clear current total.
[C]	0.0 0 0	0.0 0	0.0 0	▼				Return to Weighing mode.
[+]	t O t A L	0	0.0 0					Check total data.
[C]	0.0 0 0	0.0 0	0.0 0	▼				Return to Weighing mode.

18.6. Correction Of Past Sales Data

OPERATION	WEIGHT	U.PRICE	T.PRICE	1 - ZERO 2 - NET 3 - MEMORY 4 - BATTERY				REMARKS
				1	2	3	4	
[1] [2] [3] [4]	0.0 0 0	1 2.3 4	0.0 0	▼				Enter unit price.
Put product on platter.	2.0 0 0	1 2.3 4	2 4.6 8					
[+]	t O t A L	1	2 4.6 8			▼		Accumulation the data.
Remove product from platter.	t O t A L	1	2 4.6 8			▼		
[5] [0] [0]	0.0 0 0	5.0 0	0.0 0	▼		▼		Enter unit price.
[+]	t O t A L	2	2 9.6 8			▼		Accumulation the data .
[1] [2] [3] [4]	0.0 0 0	1 2.3 4	0.0 0	▼		▼		Enter unit price.
Put product on platter.	2.0 0 0	1 2.3 4	2 4.68			▼		
[-]	C o r r	1	5.0 0			▼		Perform past sale data correction.
[C]	2.0 0 0	0.0 0	0.0 0			▼		Return to Weighing mode.

18.7. Price Base Change By 100g/kg Key

(Available when SPEC37.3 = 0)

OPERATION	WEIGHT	U.PRICE	T.PRICE	1 - ZERO 2 - NET 3 - kg 4 - 100g 5 - MEMORY					REMARKS
				1	2	3	4	5	
[1] [0] [0]	0.0 0 0	1.0 0	0.0 0	▼		▼			Key in unit price.
[100g/kg]	0.0 0 0	1.0 0	0.0 0	▼			▼		Change price base to \$/100g.
Put product on platter.	1.0 0 0	1.0 0	1 0 0 0				▼		
[C]	1.0 0 0	0.0 0	0.0 0			▼			C key clear unit price and price base.
[100g/kg]	1.0 0 0	0.0 0	0.0 0				▼		Change price base to \$/100g.
[2] [0] [0]	1.0 0 0	2.0 0	2 0 0 0				▼		Key in unit price.
[100g/kg]	1.0 0 0	2.0 0	2.0 0				▼		Change price base to \$/kg.
Remove product, [C]	0.0 0 0	0.0 0	0.0 0	▼		▼			

18.8. Auto Zero Operation

(Available when SPEC38.1 = 0)

OPERATION	WEIGHT	U.PRICE	T.PRICE	1 - ZERO 2 - NET 3 - AUTOZERO 4 - MEMORY 5 - BATTERY					REMARKS
				1	2	3	4	5	
	0.0 0 0	0.0 0	0.0 0	▼					Weighing mode.
Put 5g on platter.	0.0 0 5	0.0 0	0.0 0						Auto Zero function is ineffective.
[AUTO ZERO]	0.0 0 0	0.0 0	0.0 0			▼			Auto Zero function is effective.
Add 20g on platter.	0.0 2 5	0.0 0	0.0 0				▼		Exceed Auto Zero range (<5e).
Remove 20g from platter.	0.0 0 0	0.0 0	0.0 0				▼		
[AUTO ZERO]	0.0 0 5	0.0 0	0.0 0						Auto Zero function is cancelled.

18.9. kg and lb conversion by UNIT Key

(Available when SPEC37.10 = 01)

OPERATION	WEIGHT	U.PRICE	T.PRICE	1 - ZERO 2 - NET 3 - \$/kg 4 - \$/lb 5 - MEMORY					REMARKS
				1	2	3	4	5	
Put product on platter.	0.5 0 0	0.0 0	0.0 0			▼			Weight in kg.
[2] [0] [0]	0.5 0 0	2.0 0	1.0 0				▼		Key in unit price in \$/kg.
Remove product, [C]	0.0 0 0	0.0 0	0.0 0	▼		▼			
[UNIT]	0.0 0 0	0.0 0	0.0 0				▼		Change to lb.
Put product on platter.	1.1 0 0	0.0 0	0.0 0				▼		Weight in lb.
[2] [0] [0]	1.1 0 0	2.0 0	2.2 0				▼		Key in unit price in \$/lb.
[UNIT]	0.5 0 0	2.0 0	1.0 0				▼		Change to kg.
Remove product, [C]	0.0 0 0	0.0 0	0.0 0	▼		▼			

18.10. kg, decimal lb and kati conversion by UNIT Key

(Available when SPEC37.10 = 10)

OPERATION	WEIGHT	U.PRICE	T.PRICE	1 - ZERO 2 - NET 3 - \$/lb 4 - \$/kati 5 - MEMORY					REMARKS
				1	2	3	4	5	
Put product on platter.	0.5 0 0	0.0 0	0.0 0						Weight in kg.
[2] [0] [0]	0.5 0 0	2.0 0	1.0 0						Key in unit price in \$/kg.
Remove product, [C]	0.0 0 0	0.0 0	0.0 0	▼					
[UNIT]	0. 0 0	0.0 0	0.0 0			▼			Change to decimal lb.
Put product on platter.	1. 1.6	0.0 0	0.0 0			▼			Weight in decimal lb.
[2] [0] [0]	1. 1.6	2.0 0	2.2 0			▼			Key in unit price in \$/lb.
Remove product, [C]	0.0 0 0	0.0 0	0.0 0	▼		▼			
[UNIT]	0. 0 0	0.0 0	0.0 0				▼		Change to kati.
Put product on platter.	0.1 3.2	0.0 0	0.0 0				▼		Weight in kati.
[2] [0] [0]	0.1 3.2	2.0 0	1.6 5				▼		Key in unit price in \$/kati.
[UNIT]	0.5 0 0	2.0 0	1.0 0						Change to kg.
Remove product, [C]	0.0 0 0	0.0 0	0.0 0	▼					

18.11. Currency Conversion by EURO Key

(Available when SPEC37.2 = 0)

18.11.1. Currency Conversion Operation Method 1 (SPEC4.32 = 01)

OPERATION	WEIGHT	U.PRICE	T.PRICE	1 - ZERO 2 - NET 3 - MEMORY 4 - BATTERY				REMARKS
				1	2	3	4	
Put product on platter.	0.5 0 0	0.0 0	0.0 0					
[2] [0] [0]	0.5 0 0	2.0 0	1.0 0					Key in unit price.
[EURO]		E U R O	2.2 0					Display re-calculated total price in secondary currency. Assume SPEC26.3 = 1, conversion rate is 2.20.
[EURO]	0.5 0 0	2.0 0	1.0 0					Return to Weighing Mode.

18.11.2. Currency Conversion Operation Method 2 (SPEC4.32 = 10)

OPERATION	WEIGHT	U.PRICE	T.PRICE	1 - ZERO 2 - NET 3 - MEMORY 4 - BATTERY				REMARKS
				1	2	3	4	
Put product on platter.	0.5 0 0	0.0 0	0.0 0					
[2] [0] [0]	0.5 0 0	2.0 0	1.0 0					Key in unit price.
[EURO]		E U R O	4.4 0					Display re-calculated unit price & total price in secondary currency. Assume SPEC26.3 = 1, conversion rate is 2.20.
[EURO]	0.5 0 0	2.0 0	1.0 0					Return to Weighing Mode.

19. Operations of Mode Set Key

19.1. Mode Change Using Mode Set Key

OPERATION	WEIGHT	U.PRICE	T.PRICE	1 - ZERO 2 - NET 3 - MEMORY 4 - BATTERY				REMARKS
				1	2	3	4	
2kg on the platter	2.000	0.00	0.00					Weighing mode.
[M] [M]	PLU	0	Code					Depress [M] key twice within 3 seconds, enter PLU setting mode.
[M]	PSEt							Preset key setting mode.
[M]	2.000	0.00	0.00					Return to Weighing mode.

19.2. PLU Setting

OPERATION	WEIGHT	U.PRICE	T.PRICE	1 - ZERO 2 - NET 3 - MEMORY 4 - BATTERY				REMARKS
				1	2	3	4	
	2.000	0.00	0.00					Weighing mode.
[M] [M]	PLU	0	Code					PLU setting mode.
[1] [0]	PLU	10	Code					Enter plu code. *Note1
[*]	PLU	0.00	UP					Display current unit price in PLU.
[1] [5] [0]	PLU	1.50	UP					Enter unit price.
[*]	PLU	0.000	tArE					Display current tare in PLU. *Note2
[1] [0] [0]	PLU	0.100	tArE					Enter tare. *Note2
[*]	PLU	0	Code					Store PLU.
[M] [M]	2.000	0.00	0.00					Return to Weighing mode.
[1] [0] [CODE]	1.900	1.50	2.85		▼			Call up PLU.
[C]	2.000	0.00	0.00					Clear PLU.

*Note1: Valid code number is 1 - 99.

*Note2: When PLU tare is allowed by SPEC28.2 = 0.

19.3. Preset Key Setting

19.3.1. Preset Key Setting when PLU function is allowed.

(When SPEC36.0 = 0)

OPERATION	WEIGHT	U.PRICE	T.PRICE	1 - ZERO 2 - NET 3 - MEMORY 4 - BATTERY				REMARKS
				1	2	3	4	
	2.000	0.00	0.00					Weighing mode.
[M] [M]	PLU	0	Code					PLU setting mode.
[M]	PSEt							Preset key setting mode.
[PRESET 1]	PSEt PLU	20						Display current PLU code in PRESET.
[C]	PSEt	0						Clear PRESET.
[1] [0]	PSEt	10						Enter PLU code.
[*]	PSEt							Store PRESET.
[M]	2.000	0.00	0.00					Return to Weighing mode.
[PRESET 1]	1.900	1.50	2.85		▼			Call up PLU set in PRESET 1.
[C]	2.000	0.00	0.00					Clear PLU.

19.3.2. Preset Key Setting when PLU function is inhibited.

(When SPEC36.0 = 1)

OPERATION	WEIGHT	U.PRICE	T.PRICE	1 - ZERO 2 - NET 3 - MEMORY 4 - BATTERY				REMARKS
				1	2	3	4	
	2.000	0.00	0.00					Weighing mode.
[M] [M]	P.S E t	0.00						Preset key setting mode.
[1] [5] [0]	P.S E t	1.50						Enter unit price.
[PRESET 1]	P.S E t	0.00						Store unit price to PRESET1.
[T]	P.S E t	0.000	t A r E					Change to set tare mode. *Note1
[1] [0] [0]	P.S E t	0.100	t A r E					Enter tare. *Note1
[PRESET 2]	P.S E t	0.00						Store tare to PRESET2. *Note1
[M]	2.000	0.00	0.00					Return to Weighing mode.
[PRESET 2]	1.900	0.00	0.00		▼			Call up tare set in PRESET 2.
[PRESET 1]	1.900	1.50	2.85		▼			Call up unit price set in PRESET 1.
[C]	1.900	0.00	0.00		▼			Clear unit price.
Remove product from platter	- 0.100	0.00	0.00		▼			
[T]	0.000	0.00	0.00	▼				Clear tare.

*Note1: When Preset tare is allowed by SPEC28.2 = 0.

19.4. Conversion Rate Setting

(Available when SPEC37.2 = 0)

OPERATION	WEIGHT	U.PRICE	T.PRICE	1 - ZERO 2 - NET 3 - MEMORY 4 - BATTERY				REMARKS
				1	2	3	4	
	2.000	0.00	0.00					Weighing mode.
[M] [M]	P L U	0	C o d E					PLU setting mode.
[M]	P.S E t							Preset key setting mode.
[M]	E U R O	r A t E	0					Enter into conversion rate setting mode.
[2] [2] [0]	E U R O	r A t E	2.20					Set conversion rate to 2.20.
[M]	2.000	0.00	0.00					Return to Weighing mode.

19.5. Invert Currency Conversion Function

(Available when SPEC37.2 = 0 and SPEC35.0 = 0)

OPERATION	WEIGHT	U.PRICE	T.PRICE	1 - ZERO 2 - NET 3 - MEMORY 4 - BATTERY				REMARKS
				1	2	3	4	
	2.000	0.00	0.00					Weighing mode.
[M] [M]	P L U	0	C o d E					PLU setting mode.
[M]	P.S E t							Preset key setting mode.
[M]	E U R O	R A t E	0					Enter into conversion rate setting mode.
[RE-ZERO]	88888	88888	888888					Enter 2001 while pressing RE-ZERO.
[RE-ZERO] + [2] [0] [0] [1]		E U R O	InvErt					EURO conversion function is inverted.
[M]	2.000	0.00	0.00					Return to Weighing mode.

*Note: When Invert Currency Conversion Function operation is performed, following change will be made internally:

- 1) The data set in SPEC22.10 and SPEC34.32 is exchanged.
- 2) Set SPEC35.2 = 0; SPEC35.1 = 0; SPEC35.0 = 1.

19.6. Cancel Currency Conversion Function

(Available when SPEC37.2 = 0)

OPERATION	WEIGHT	U.PRICE	T.PRICE	1 - ZERO 2 - NET 3 - MEMORY 4 - BATTERY				REMARKS
				1	2	3	4	
[M] [M]	2.0 0 0	0.0 0	0.0 0					Weighing mode.
[M]	PLU	0	C o d E					PLU setting mode.
[M]	P.S E t							Preset key setting mode.
[M]	E U R O	RA t E	0					Enter into conversion rate setting mode.
[RE-ZERO]	8 8 8 8 8	8 8 8 8 8	8 8 8 8 8 8					Enter 2 0 0 2 while pressing RE-ZERO.
[RE-ZERO] + [2] [0] [0] [2]		E U R O	CAnCEL					EURO conversion function is cancelled.
[M]	2.0 0 0	0.0 0	0.0 0					Return to Weighing mode.

*Note: When Cancel Currency Conversion Function operation is performed, SPEC37.2 is set to 1 internally:

20. RS-232C Interface

20.1. Specification

Baud Rate : 1200 / 2400 / 4800 / 9600 / 19200 / 38400 BPS.

Start Bit : 1 Bit.

Stop Bit : 1 / 2 Bit.

Date Bit : 7 / 8 Bits.

Parity Bit : Even / Odd / None.

20.2. Pin Assignment

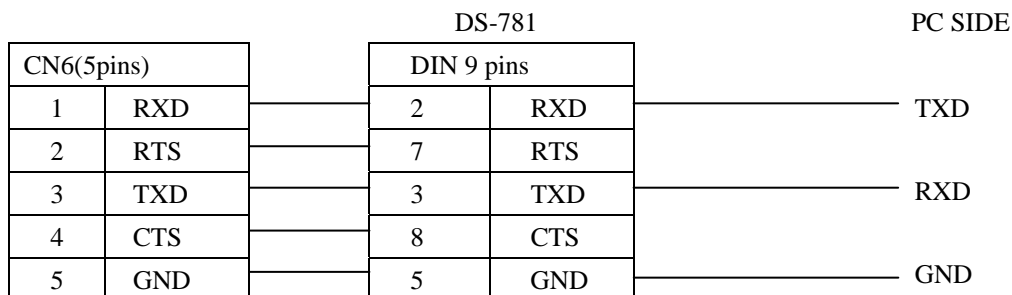

*Note: RTS/CTS handshaking function is effective only when SPEC3.3 = 0.

20.3. Control Code and Characters

Termination Code	CR	The end of data	0x0d
	LF	The end of Text	0x0a
Date	'0' ~ '9'	Numeric date	0x30 ~ 0x39
	'-' (Minus)	Minus sign	0x2d
	'.' (Decimal)	Decimal	0x2e
	' ' (Space)	Data error or empty	0x20
	OF	Overflow	0x4f 0x46
	UF	Underflow	0x55 0x46
Header Code	'0'	Net Weight	0x30
	'4'	Tare Weight	0x34
	'U'	Unit Price	0x55
	'T'	Total Price	0x54
	ENQ	Enquiry	0x05

Command	ACK	Acknowledge	0x06
	NAK	Not Acknowledge	0x15

20.4. Data Format

A) Without additional parity (Total 37 Bytes)

Status Flag	Weight Condition Flag	CR	Header Code	Net Weight	CR	Header Code	Tare Weight
1 Byte	1 Byte	1 Byte	1 Byte	6 Bytes	1 Byte	1 Byte	6 Bytes



CR	Header Code	Unit Price	CR	Header Code	Total Price	CR	LF
1 Byte	1 Byte	6 Bytes	1 Byte	1 Byte	7 Bytes	1 Byte	1 Byte

B) With additional parity (Total 38 Bytes)

Status Flag	Weight Condition Flag	CR	Header Code	Net Weight	CR	Header Code	Tare Weight
1 Byte	1 Byte	1 Byte	1 Byte	6 Bytes	1 Byte	Byte	6 Bytes



CR	Header Code	Unit Price	CR	Header Code	Total Price	CR	Additional Parity	LF
1 Byte	1 Byte	6 Bytes	1 Byte	1 Byte	7 Bytes	1 Byte	1 Byte	1 Byte

*Note: If the additional parity is 0x0d, 0x0a or 0x00, it will be changed to 0x1d, 0x1a or 0x10 respectively.

Status Flag:

Not Used	Fixed to 1	Not used	Price Base	Price Base	Total Price Overflow	Net	Additional Parity
----------	------------	----------	------------	------------	----------------------	-----	-------------------

Bit 7 : Not used. Always 0;

Bit 6 : Fixed to 1.

Bit 5 : Not used.

Bit 4 and Bit 3 : Price Base. 00 - \$/kg, 01 - \$/100g, 10 - \$/1b, 11 - \$/1/41b.

Bit 2 : Total Price Overflow. Set to 1 when total price overflow, 0 when not.

Bit 1 : Net. Set to 1 When tare subtraction is performed, 0 when not.

Bit 0 : Additional parity flag. Set to 1 when additional parity code is added in text, 0 when not.

Weight Condition Flag:

Not Used	Fixed to 1	Not used	Weight UF	Weight OF	Negative Net Weight	Weight Stable	Zero Sign
----------	------------	----------	-----------	-----------	---------------------	---------------	-----------

- Bit 7 : Not used. Always set 0.
- Bit 6 : Fixed to 1.
- Bit 5 : Not used.
- Bit 4 : Weight UF. Set to 1 when weight underflow, 0 when not.
- Bit 3 : Weight OF. Set to 1 when weight overflow, 0 when not.
- Bit 2 : Negative Net Weight. Set to 1 when net weight is negative, 0 when not.
- Bit 1 : Weight Stable. Set to 1 when weight is stable. 0 when not.
- Bit 0 : Zero Sign. Set to 1 when weight zero sign is set. 0 when not.

Example1: Transmit all data.

Net weight = 3.456 Tare weight = 1.200 Unit Price = 1.500 (\$/kg)
 Total Price = 5.184 Weight status : stable

Status Flag: 0x42

0	1	0	0	0	0	1	0
---	---	---	---	---	---	---	---

Weight Condition Flag: 0x42

0	1	0	0	0	0	1	0
---	---	---	---	---	---	---	---

By ASCII Code:

0x42	0x42	0x0d	0x30	0x30	0x33	0x2e	0x34	0x35	0x36	0x0d
------	------	------	------	------	------	------	------	------	------	------

0x34	0x30	0x31	0x2e	0x32	0x30	0x30	0x0d
------	------	------	------	------	------	------	------

0x55	0x30	0x31	0x2e	0x35	0x30	0x30	0x0d
------	------	------	------	------	------	------	------

0x54	0x30	0x30	0x35	0x2e	0x31	0x38	0x34	0x0d	0x0a
------	------	------	------	------	------	------	------	------	------

Example2: Only transmit Net weight and Total Price.

0x42	0x42	0x0d	0x30	0x30	0x33	0x2e	0x34	0x35	0x36	0x0d
------	------	------	------	------	------	------	------	------	------	------

0x54	0x30	0x30	0x35	0x2e	0x31	0x38	0x34	0x0d	0x0a
------	------	------	------	------	------	------	------	------	------

Example3: When weight is overflow, the following data is output.

0x42	0x48	0x0d	0x30	0x20	0x20	0x20	0x20	0x4f	0x46	0x0d
------	------	------	------	------	------	------	------	------	------	------

0x34	0x30	0x31	0x2e	0x32	0x30	0x30	0x0d
------	------	------	------	------	------	------	------

0x55	0x30	0x31	0x2e	0x35	0x30	0x30	0x0d
------	------	------	------	------	------	------	------

0x54	0x20	0x20	0x20	0x20	0x20	0x20	0x20	0x0d	0x0a
------	------	------	------	------	------	------	------	------	------

20.5 Communication Method

The data communication method can be selected from Stream(continuous), Manual, and Command by specification settings.

20.5.1 Type A (Standard Stream)

Data is transmitted to PC side continuously.

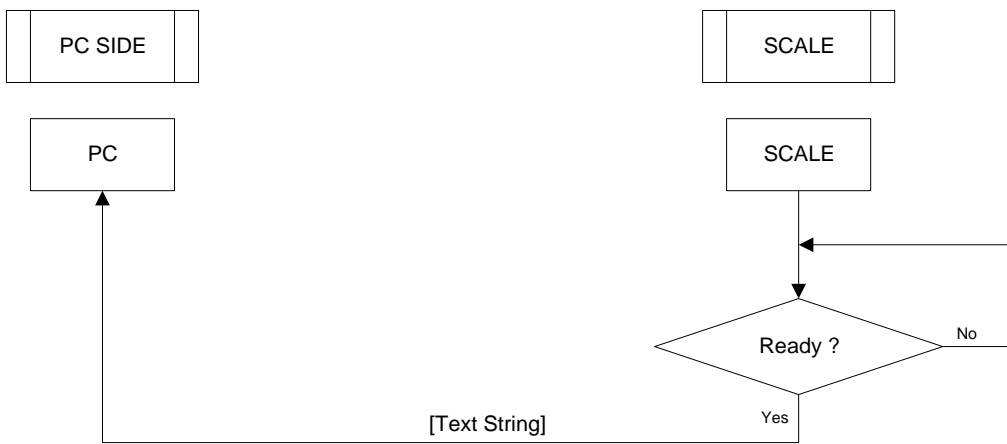

Note: Weight stable check depends on SPEC setting.

20.5.2 Type W (Standard Manual)

Data is output by pressing Manual key(+ key). User may select to transmit the data right away or hold the command until weight become stable by specification setting.

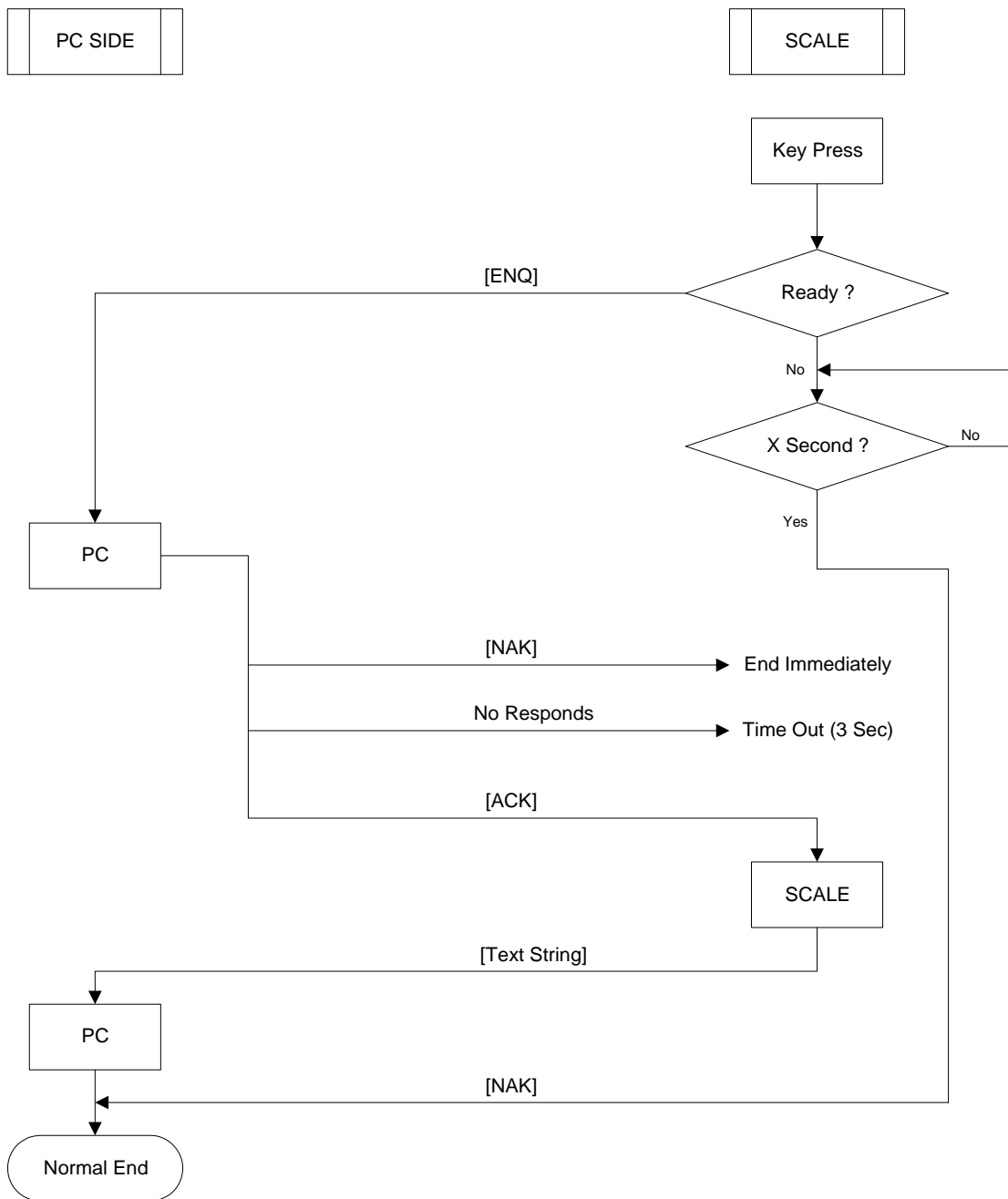

Note: Weight stable check depends on SPEC setting.

20.5.3 Type B (Standard Command)

The data transmission starts by receiving the command from external (Ex. PC side).

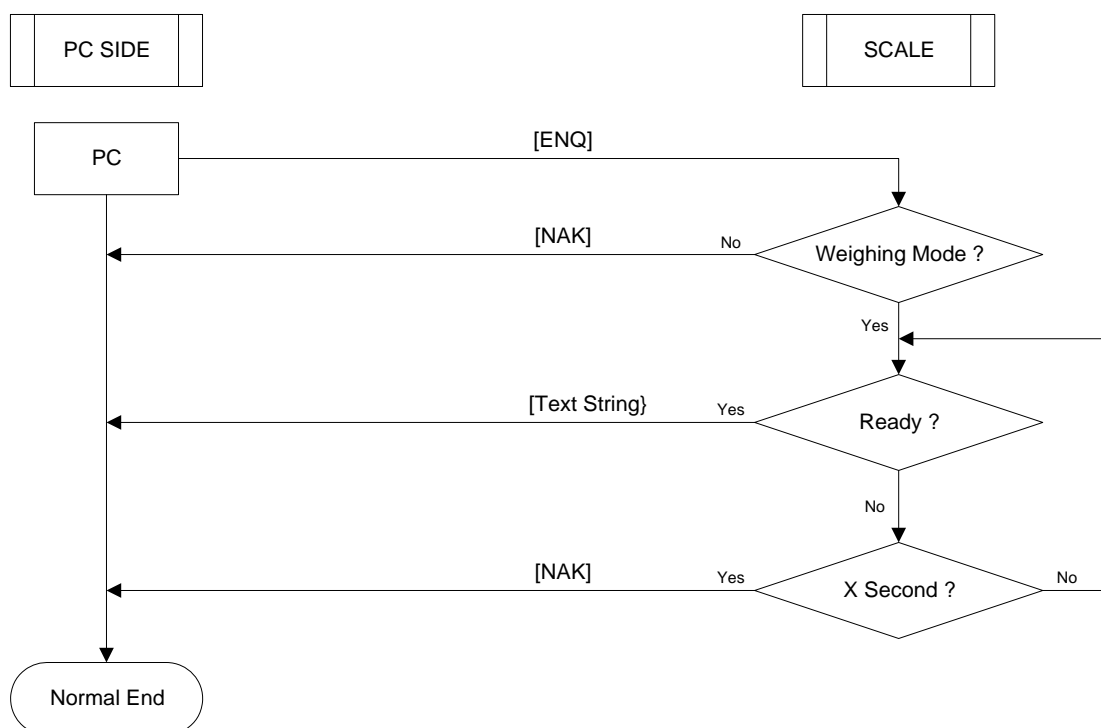

*Note: Weight stable check depends on SPEC setting.

21. Error Message List

The following error message will appear when an incorrect operation is performed.

Message	Remarks	Appropriate Operation
8 8 8 8 8 8	When scale is not steady when power on.	Place scale on firm, flat base.
O F	When weight exceeds capacity+9d, or something is on the platter when power on.	Remove the item on the platter.
U F	When negative weight exceeds display limit.	REZERO or ON/OFF again.
Total FULL	When current Total overflow.	Clear current Total.
E r r o r	When error occurs in maintenance mode.	Repeat operation.
E R R 01	When A/D error.	Contact dealer.
E R R 02	When data flash erase error.	Contact dealer.
E R R 03	When data flash program error.	Contact dealer.